

Instruction Manual

for

POWER  HAND[®] 2X

**Recipro Handpiece
Model: Z-2X**

#510-2150



Gesswein[®]
The Right Tools Since 1914

Introduction

Gesswein Power Hand 2X Recipro handpieces are manufactured to the highest standards available to provide many years of trouble-free service. Complete with Powerful 30V DC aircooled motors and sealed bearings. Backed by a limited warranty that covers wear parts for 90 days and overall balance of parts for six months.

This DC electrically driven Recipro handpiece is designed to be used with Gesswein Power Hand 2X Single, Standard, Dual, Jewelers' Micromotor, Power Carver II and Bright-Cutting Controllers. These controllers convert the Alternating Current (AC) power supply to a variable Direct Current (DC) by means of an I.C. "transistorized" automatically controlled circuit.

Specifications

Speed Range (RPM)	
Dual or Single Controller*	0-117
Standard Controller	29-117
Input Voltage	
	3-30V
Length of Stroke	
	0-2.0mm
Max. Shaft Output (W/sec.)	
Dual Controller	50
Standard Controller	32.5
Single Controller	33.8
Max. Stoppage Torque (ft.-lbs./N-m**)	
Dual Controller	0.056/0.076
Standard Controller	0.048/0.065
Single Controller	0.053/0.072
Net Wt. (without power cord)	
	24 oz.

*Or Standard Controller with variable-speed foot rheostat

**Foot-pounds/Newton-meters

1. Accessories

Included Accessories

- A. One Pin Tool
- B. One Allen Wrench
- C. One Bottle Spindle Oil
- D. One Assortment of Tool Holders, Bamboo Laps, PSA Chips and Felt Pads

Optional Accessories

- A. Handpiece Extension Cord (#510-1120): adds 6', or almost 2m, to the 1.7m hand-piece cord
- B. Handpiece Cradle Rest (#510-1130): provides safe holding place for handpiece when not in use
- C. Variable-Speed Foot Rheostat (#510-3100)
- D. On/Off Foot Switch (#510-3105)

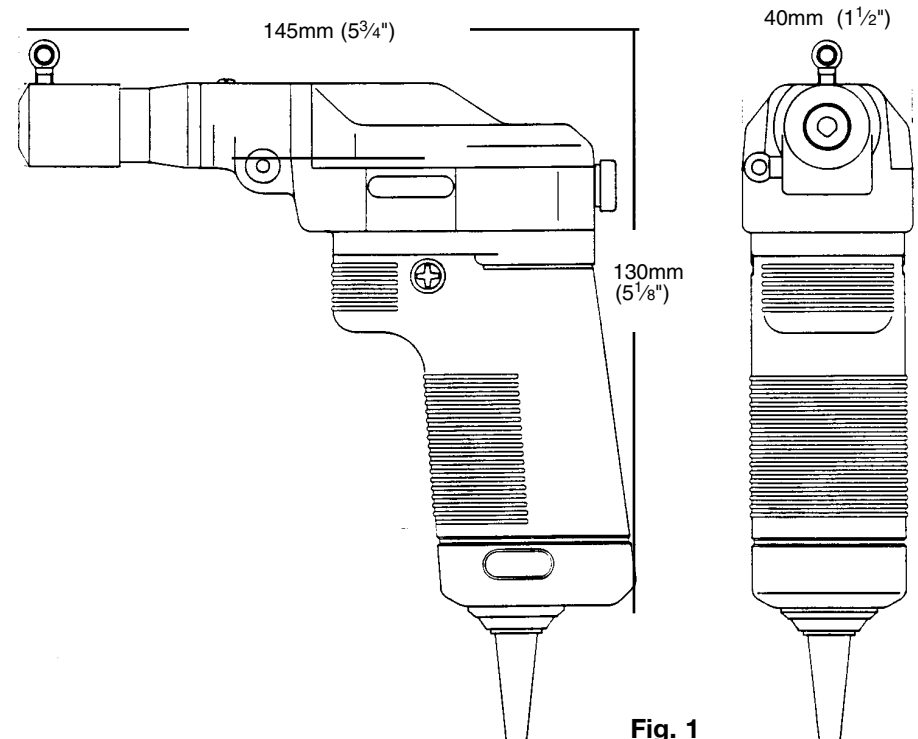

Fig. 1

2. Parts Nomenclature

1. Spindle
2. Tool-Securing Screw
3. Lubrication Hole
4. Floating Head-Securing Knob
5. Body
6. Cover
7. Cover Screw
8. Grip
9. Strain Relief
10. Electric Cord with 3-Pin Plug
11. Eccentric Collar
12. Eccentric Shaft
13. Hex Socket Set Screw
14. Eccentricity Indicator
15. Crank Shaft
16. Crank Shaft Set Screw
17. Ball Joint
18. Pulley
19. Drive Belt

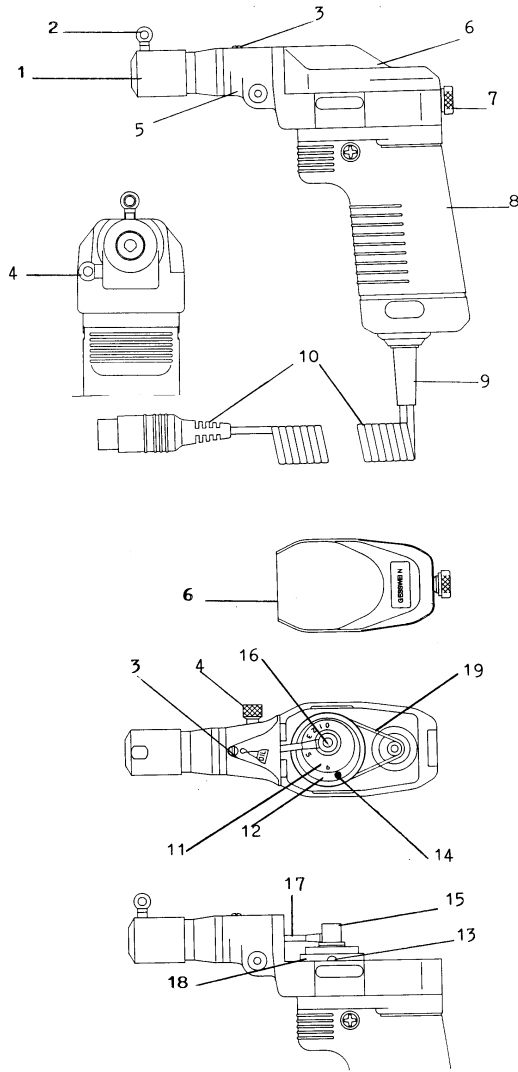

Fig. 2

3. General Use

Tool Holder

The Recipro handpiece Spindle is designed to accept tools with shank diameters from 1.5 to 4.0mm. To insert the desired polishing tool into the spindle aperture, turn the Tool-Securing Screw counterclockwise either by hand or with the tool pin provided (see fig. 3). Once the tool has been inserted, be sure to tighten securely by rotating the Tool-Securing Screw back in the clockwise direction.

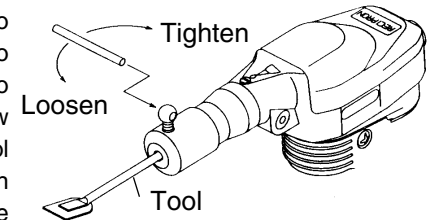

Fig. 3

Stroke Adjustment

Remove the Recipro handpiece Cover by unfastening the Cover Screw located at the rear. The Hex Socket Set Screw is located on the side of the Eccentric Shaft. Loosen this set screw with the provided Allen Wrench (see fig. 4). Stroke lengths are graduated in millimeters (1.0mm = 0.4") and indicated by red numbers on the Eccentric Collar. Hold the Recipro in one hand with stroke adjustment numbers facing you, and press your thumb against the Eccentric Shaft. With your free hand, turn the Eccentric Collar until the selected stroke length lines up with the red Eccentricity Indicator. Now tighten the set screw and replace the handpiece cover.

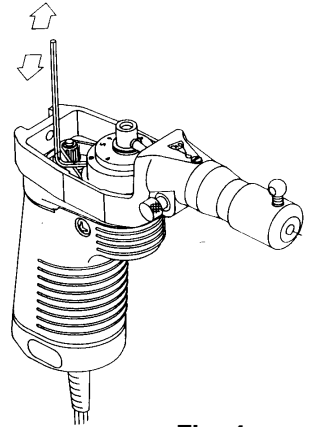

Fig. 4

Floating Head

The Recipro handpiece has been designed to allow the efficient polishing of both curved and flat surfaces. Better control can be maintained on a curved work surface if the tool can float so it is always in contact with the surface. When the Recipro handpiece is in its floating head position, the selected tool will revolve around its axis 360° in both directions while reciprocating. The normal fixed head position is used for flat surfaces and holds the tool parallel to the surface being polished.

To use the Floating Head feature, turn the Floating Head-Securing Screw counterclockwise (see fig. 5). In this position the head will rotate freely around its axis while polishing. To return to the position of fixed reciprocation, turn the securing screw clockwise.

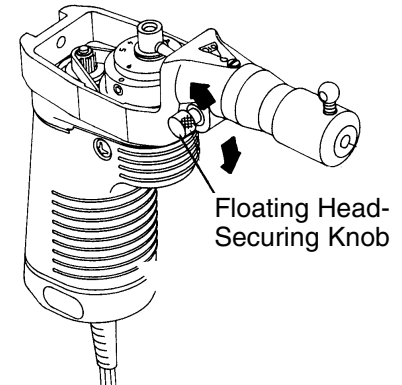

Fig. 5

4. Operating Procedure

With your Recipro handpiece adjusted for stroke and with a selected tool fitted, connect the Gesswein Power Hand Controller to an electrical supply and the Recipro to Controller.

Set the slide Rheostat on the controller to “Low” or the “0” position. Put the Controller Main Switch to the “ON” position, which lights up a pilot light that indicates your Recipro is ready to use.

To increase the speed of the Recipro handpiece, move the Slide Rheostat toward “High” or “10” and the desired reciprocating frequency and begin working. When the work is completed, put the Main Switch to “OFF.”

To operate your Recipro by using the optional Variable-Speed Foot Rheostat or optional On/Off Foot Switch, please refer to the Power Hand Controller Instruction Manual for proper connection. The handpiece will not reciprocate until the foot rheostat/switch is depressed. The rheostat provides infinitely variable speed control; the switch only turns handpiece on and off (operates at speed selected on control unit).

5. Precautions

- A.** For your personal safety, do not operate the Recipro handpiece with the cover removed. Operation without the cover secured with the cover screw can cause foreign objects to fall into the high-speed moving cam parts, causing bodily injury and handpiece damage.
- B.** Before operating your Recipro, be sure the desired tool is properly secured in the spindle aperture.
- C.** Do not attempt to change tools or use the floating head feature while the handpiece is operating.
- D.** During use, avoid pushing too hard on the work tool or exceeding torque capacity of the Recipro motor.
- E.** After stoning operations with lubricants, prevent oil-abrasive slurry from entering the handpiece by holding the Recipro with spindle pointed down.
- F.** When the Recipro is used against vertical walls of a workpiece, a hammering effect may be felt in the handpiece and work tool. Although the Recipro has a spring-loaded cushion to prevent damage caused by hammering or the restriction of stroke movements, prolonged use of this nature can cause damage to the spindle, ball joint, metal bearings and work tool.
- G.** Applications in which a sharp work tool strikes the surface of a workpiece should be avoided.
- H.** Whenever possible, avoid using the Recipro in high humidity.
- I.** Always disconnect the Recipro from the Controller by the plug, not the cord.
- J.** Under normal circumstances, the Recipro handpiece will not overheat. If your Recipro does overheat, please contact the Gesswein Repair Department.

6. Maintenance

Lubrication

It is necessary to lubricate the Recipro head assembly parts engaged in reciprocating action. Lubrication should be scheduled for this portion of your Recipro once for each eight hours of use.

The Recipro must periodically receive two small drops of oil. Lubrication is done through the Lubrication Hole after removal of the small screw (part #103 – see p. 8-9 for parts drawing) located in the top-front of the handpiece body. Two drops of light machine oil like the Spindle Oil provided with the Recipro is sufficient to keep the spindle assembly working smoothly.

Cleaning

With prolonged use of the Recipro handpiece, oil, abrasives and dust from the workplace atmosphere are likely to accumulate around and in the spindle aperture and under the body cover. This accumulation could cause malfunction and damage to moving components if not removed.

To remove the dirt from under the body cover, use a dry brush or a detergent-moistened cloth. Periodically clean the spindle aperture with a cotton swab. Do not use paint thinner or alcohol as a cleaner.

When the external surfaces of your handpiece become dirty, wipe with a cloth slightly saturated with neutral cleaning liquid. Again, do not use a volatile liquid such as paint thinner or alcohol.

Z-2X Parts List

When ordering spare parts, always specify part# (or item# if applicable) and description.

Part#	Item#	Description
Z-2X-101	8960108	Body
Z-2X-102	8960109	Spindle Metal
Z-2X-103	8960110	Lubricant Hole Screw
Z-2X-104	8960111	Clip Ring
	8960112	Spacer
Z-2X-105	8960113	Body Cover
Z-2X-106	8960114	Cover Set Screw
Z-2X-107	8960115	E-Ring
Z-2X-108	8960116	Tesion Collar
Z-2X-109	8960117	Tension Collar Set Screw
Z-2X-110	8960118	Handgrip
Z-2X-111	8960119	Oval Head Screw
Z-2X-112	8960120	Handgrip Set Screw
Z-2X-200	8960124	Spindle Complete
Z-2X-201	8960125	Tool-Securing Screw
Z-2X-202	8960126	Spindle
Z-2X-203	8960127	Rubber O-Ring
Z-2X-204	8960128	Damper
Z-2X-205	8960129	Coil Spring
Z-2X-206	8960130	Joint Base
Z-2X-207	8960131	Spacer
Z-2X-208	8960132	Ball Joint
Z-2X-209	8960133	Ball Joint Receiver
Z-2X-300	8960134	Eccentric Collar Complete
Z-2X-301	8960135	Hex Socket Set Screw
Z-2X-302	8960136	Crank Shaft
Z-2X-303	8960137	Eccentric Collar
Z-2X-304	5103078	Ball Bearing
Z-2X-305	8960139	Metal Spacer
Z-2X-306	8960060	Stainless Spacer
Z-2X-307	8960141	Wave Washer
Z-2X-308	8960142	C-Ring
Z-2X-309	8960143	Screw Ring A
Z-2X-400	8960144	Eccentric Shaft Complete
Z-2X-401	8960145	Drive Belt
Z-2X-402	8960146	Hex Socket Set Ring
Z-2X-403	8960147	C-Ring
Z-2X-404	5103082	Ball Bearing
Z-2X-405	8960149	Bearing Spacer
Z-2X-406	8960150	Stainless Spacer
Z-2X-407	8960151	Wave washer
Z-2X-408	8960152	C-Ring
Z-2X-409	8960153	Screw Ring B
Z-2X-500	8960154	Spindle Lock Complete

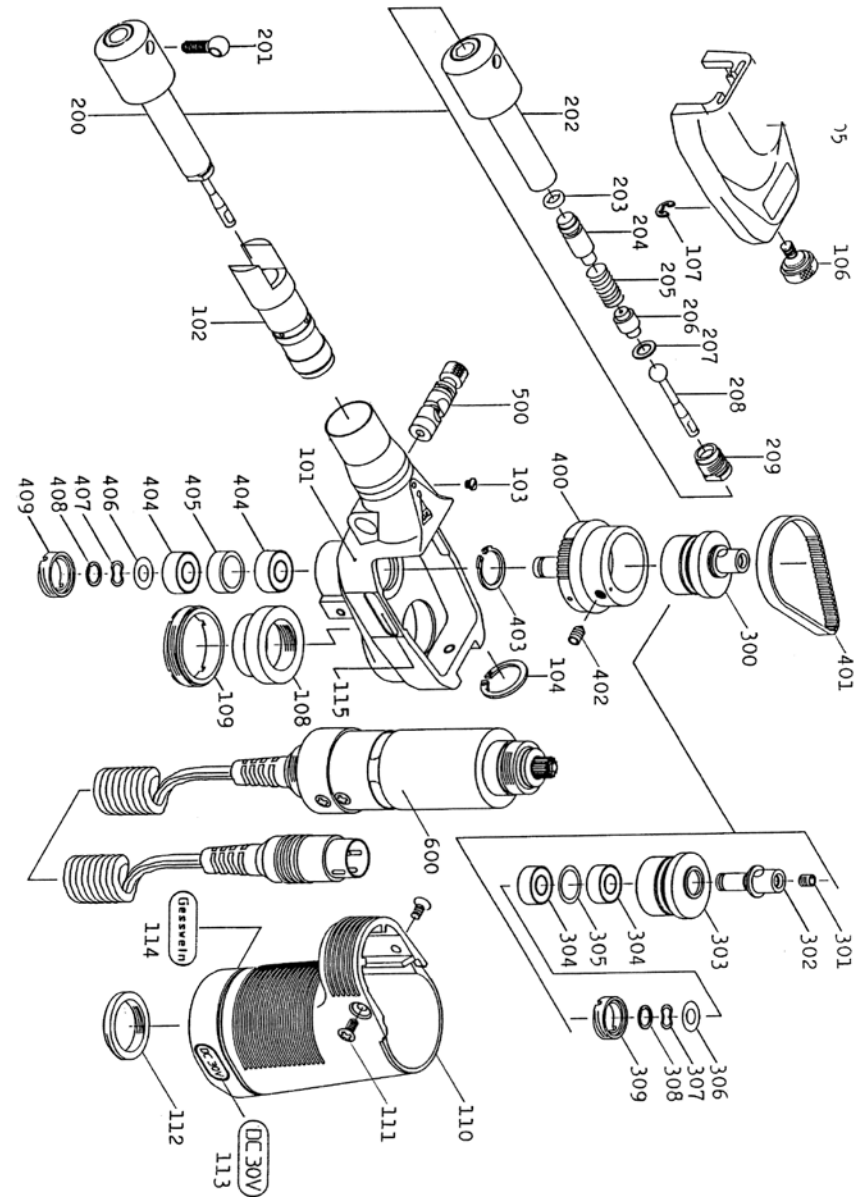

Z-2X Parts List, continued

When ordering spare parts, always specify part# (or item# if applicable) and description.

Part#	Item#	Description
Z-2X-600	8960155	Motor Complete
Z-2X-601	8960156	E-Type Clip Ring
Z-2X-602	8960157	Pulley
Z-2X-603	8960158	Motor Case
Z-2X-604	8960159	Countersunk Head Screw
Z-2X-605	8960160	O-Type Rubber Ring
Z-2X-606	8960161	Metal Spacer
	8960162	Wave Washer
	8960163	Metal Spacer
Z-2X-610	8960164	Armature Complete
Z-2X-612	8960165	Fiber Spacer
Z-2X-611	8960166	C-Type Clip Ring
	8960167	Wave Washer
Z-2X-613	8960008	Metal Spacer
Z-2X-614	5103094	Ball Bearing
Z-2X-615	8960168	Armature
Z-2X-616	5103073	Ball Bearing
Z-2X-621	8960012	O-Type Rubber Ring
Z-2X-622	8960013	Teflon Spacer
Z-2X-623	8960014	Rear Lid
Z-2X-624	8960017	Pan Head Screw
Z-2X-625	5101063	Carbon Brush
Z-2X-262	8960138	Brush Side Lid
Z-2X-267	8960148	Terminal
Z-2X-628	8960169	(-) Terminal Insulation Tube
Z-2X-629	8960170	(+) Terminal Insulation Tube
Z-2X-630	8960171	Motor Cap
Z-2X-631	8960159	Countersunk Head Screw
Z-2X-632	5100165	Cord Brush
Z-2X-633	8960174	Motor Cord with Plug
	8960175	Motor Cord with Plug Complete
Z-2X-003	8960176	Allen Wrench
Z-2X-004	8960177	Spindle Oil

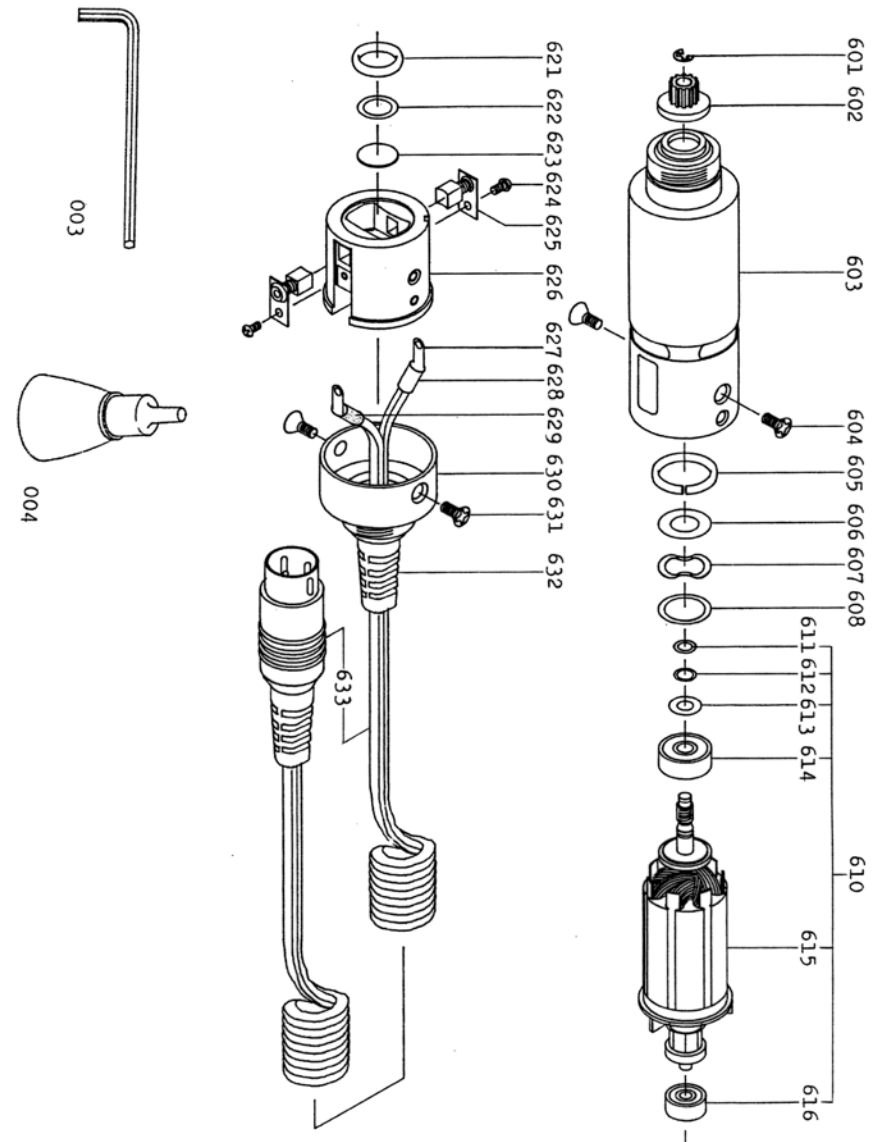



Power Hand 3 controllers and handpieces combine to create the most versatile finishing system in the industry, offering rotary, profiling and belt sanding action.

Power Hand 3 component selection:

- PH3 controller
- Six motors (three high torque, two standard, and one high speed)
- A selection of 8 heads
- Two reciprocating profilers
- One side-to-side profiler
- Belt Sander

Safety Recommendations — Prolonged use of vibrating or reciprocating tools may result in vibration-induced circulation problems in the hands. Always follow safe operating procedures. Using hand protection (i.e., insulated gloves) and taking frequent breaks can help minimize but not guarantee against injury. Operating these types of tools in cold weather or with a tight grip will reduce the period of operation before risking potential injury. Individuals with a tendency to suffer from poor circulation, frequently cold fingers or itchy hands should closely monitor the condition of their hands. If symptoms appear, seek medical advice immediately.



201 Hancock Ave. Bridgeport, CT 06605, USA
orders 800.243.4466 | 203.366.5400 | fax 203.366.3953
email info@gesswein.com | www.gesswein.com